

Waste King

C O M M E R C I A L

by Anaheim Manufacturing

5000-3

5 HP ■ 3 Phase ■ 6" Throat

5000-38

5 HP ■ 3 Phase ■ 8" Throat

5000-38S

5 HP ■ 3 Phase ■ 8" Throat
(22³/₈" overall minimum height)

COMMERCIAL FOOD WASTE DISPOSER SPECIFICATIONS

APPLICATION HIGH VOLUME, MASS FEEDING OPERATIONS WHERE PEAK LOADS ARE EXTREME AND VOLUME OF DIFFICULT WASTE IS CONTINUOUS OR VERY HEAVY. FOR EXAMPLE, A LARGE FACTORY RESTAURANT OR A HOTEL.

WASTE KING® EXCLUSIVES

- Stainless Steel Swivel Impellers swivel and retract if they are jammed so that they return to the grinding position during revolution, reducing motor overloading and costly jams. Waste King's stainless steel swivel impellers eliminate the need for reversing switches and special "de-jamming" wrenches.
- Stainless Steel Undercutter Blade located beneath the grind ring snips fibrous and stringy waste into small particles making them less likely to clog drain lines.
- Hush-Cushions® isolate the unit from metal to metal contact, significantly reducing noise level. Hush-Cushions® are specially compounded and designed to withstand vibration and tension, and have a built-in safety splash guard.

FEATURES

- 5 HP disposer, dual voltage
- Fan cooled motor with ball bearing construction and integral overload protection
- Dynamically balanced for smooth long wearing operation
- Hush Cushion® mounting connection for 6" or 8" cone or sink opening
- Cast iron grind chamber with directional feeder ridges
- Cast iron exit chamber with auxiliary water injection inlet
- 10" Diameter heavy duty, cast stainless steel turntable
- 3 Jam resistant, hardened stainless steel swivel impellers with tungsten carbide inserts
- 6 Ripper bars integrated with turntable and hard face beaded edge for prolonged life
- Stainless steel undercutter blade
- Hard, tough, cast alloy grind ring with dual stage grinding action
- Lifetime particle size control by non-wearing exit slots
- Threaded adjustable stainless steel legs



MOUNTING SYSTEMS

Sink Mount Assembly (SM)

- #2542 3¹/₂" Bolt-in adapter for leg-supported models with 6" throat

Trough Mount Assembly (TM)

- #2536 6" Weld-in flange for models with 6" throat or
#2540 8" Weld-in flange for models with 8" throat

Basic Cone Assembly (B)

- 12", 15", or 18" Cone with Swirl Sprays

All-Purpose Cone Assembly (AP)

- 12", 15", or 18" Cone with Swirl Sprays
- Silver Guard
- Scrap Ring

Dish Table Cone Assembly (DT)

- 12", 15", or 18" Cone with Swirl Sprays
- 12", 15", or 18" Cone Cover
- Scrap Ring

NOTE: For Models 5000-38 and 5000-38S, specify 8" throat.

Add desired Waste King water controls, switch or panel control box to complete your package. (See catalog)

PLUMBING Models 5000-3, 5000-38, and 5000-38S are equipped with a drain outlet for connection to a conventional 3" trap. The trap may be connected to a 3" branch waste line running directly into a waste stack. We recommend a slope in the waste line of not less than 1/4" per foot. Limit the 3" drain line to a turn free run of 15', then connect to a 4" or 6" line or stack. Connect directly to waste line, not through a grease interceptor.

MOTOR DATA

5000-3, 5000-38, and 5000-38S

- 60 cycle
- 3 Phase
- 5 HP
- 1740 RPM
- 208-220/440 volts
- 16.0/8.0 amps

Bearing permanently lubricated.
Manual reset overload protection in motor.

TO SPECIFIERS So that you may be assured of receiving the fine quality you expect when you specify a WASTE KING® FOOD WASTE REMOVAL SYSTEM, we include the following sample specification for your convenience:

- Food waste disposer shall be 5 HP, 60 cycle, 3 Phase with 208-220/440v.
- There shall be a rubber Hush Cushion® between the disposer and the cone or sink to eliminate metal to metal contact.
- Turntable shall be of stainless steel with jam-resistant swivel impellers of hardened stainless steel with Tungsten carbide inserts.
- Turntable shall have stainless steel cutting blade rotating below the exit slots.
- Grind ring shall be precision ground on all cutting surfaces and shall have non-wearing size controlled exit slots.
- Disposer shall have a totally enclosed, continuous duty, fan cooled motor with integral overload protection.
- Unit shall be Waste King® model 5000-3, 5000-38 or 5000-38S.

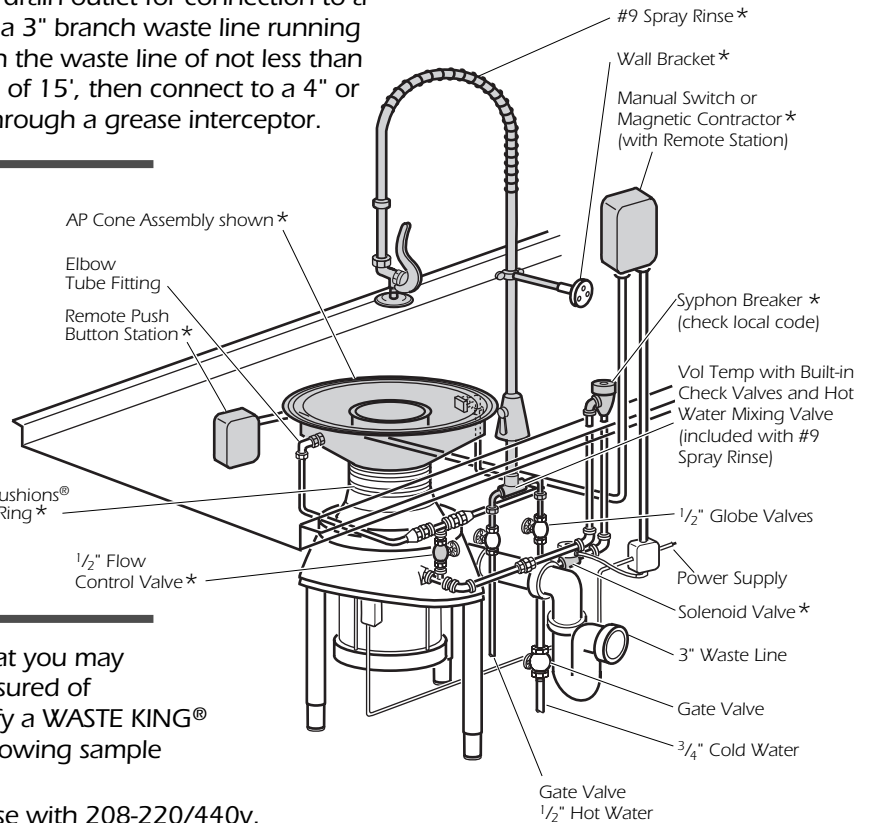

NOTE:

1. Disposer assembly includes disposer, mountings, and drain outlet. Other items shown in gray are available in mounting systems or ordered separately.
2. Installation should be made in accordance with local codes.
4. All specifications subject to change without notice.
3. Assembly should be installed in accordance with Waste King's printed installation instructions.

* Items available through Waste King

ROUGH-IN DIMENSIONS WITH DRAIN LINE CONNECTIONS

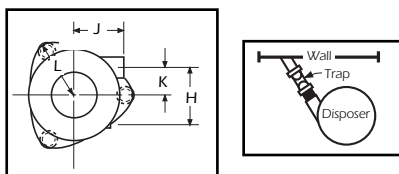
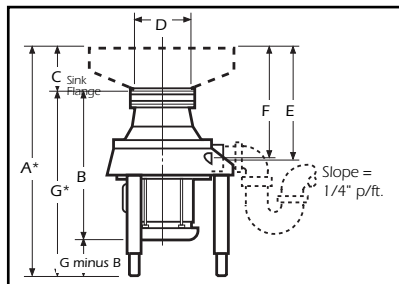

	Model 5000-3		Model 5000-38		Model 5000-38S			
	IN	CM	IN	CM	IN	CM		
A	32 ⁷ / ₈ -35 ³ / ₈	83.2-89.9	A	33-35 ¹ / ₂	83.7-90.1	A	29-35 ¹ / ₂	73.7-80
B	22 ¹ / ₂	57.3	B	22 ¹ / ₂	57.3	B	20 ³ / ₈	51.7
C	6 ⁵ / ₈	16.8	C	6 ⁵ / ₈	16.8	C	6 ⁵ / ₈	16.8
D	6	15.2	D	8	20.3	D	8	20.3
E	17 ³ / ₈	43.9	E	17 ³ / ₈	43.9	E	15 ¹ / ₈	38.4
F	16 ⁵ / ₈	42.2	F	16 ⁵ / ₈	42.2	F	14 ¹ / ₂	36.2
G	26 ¹ / ₄ -28 ³ / ₄	66.9-73.0	G	26 ³ / ₈ -28 ⁷ / ₈	66.9-73.0	G	22 ³ / ₈ -24 ⁷ / ₈	56.8-63.2
H	8 ¹ / ₂	21.4	H	8 ¹ / ₂	21.4	H	8 ¹ / ₂	21.4
J	8	20.4	J	8	20.4	J	8	20.4
K	4 ³ / ₄	12.1	K	4 ³ / ₄	12.1	K	4 ³ / ₄	12.1
L	10 ¹ / ₄	25.8	L	10 ¹ / ₄	25.8	L	10 ¹ / ₄	25.8

NOTE:

The legs can be cut shorter if the unit must be lower than the minimum shown for the screw adjustment. 2" clearance must be maintained beneath the motor for ventilation. For example, on a flat floor models 5000-3 and 5000-38 can be shortened by 1 1/2". If space between disposer and wall is insufficient to allow for installation of trap, waste line may have to be at an angle to the wall as shown. See disposer leg modification instructions.